

# PORTABLE SCREW COMPRESSOR PDSF920S



**HIGH PRESSURE:150PSIG  
FAD:920CFM**

## Main Improvements:

### ◆ Highly Recognized Screw Compressor

Screw rotor profile developed by AIRMAN own technology(patented in eight countries as well as in Japan) has enabled us to make such high pressure screw compressor.

### ◆ Clean Engine Mounted

On the compressor is mounted such engine which emits less NOx exhaust gas and also is tender to the earth enviroment.

### ◆ Easy Starting in Cold Weather

This compressor is superior in cold weather starting.

### ◆ Meters with Luminous Lights

Meters on operation panel are equipped with luminous light.

### ◆ Reliable Warning Signal

Warning signals have luminiscent diode and so become more reliable.

### ◆ Double Element Air Cleaner

Double element air cleaner prevents dust from entering when replacing element.

### ◆ Easy Cleaning of Cooling System

This compressor is so designed that the interiors of radiator and oil cooler and also fuel tank can be easily and quickly cleaned.

### ◆ Check Valve in Service Air Line

As a Check valve is built-in service air line , it enables parallel operation.

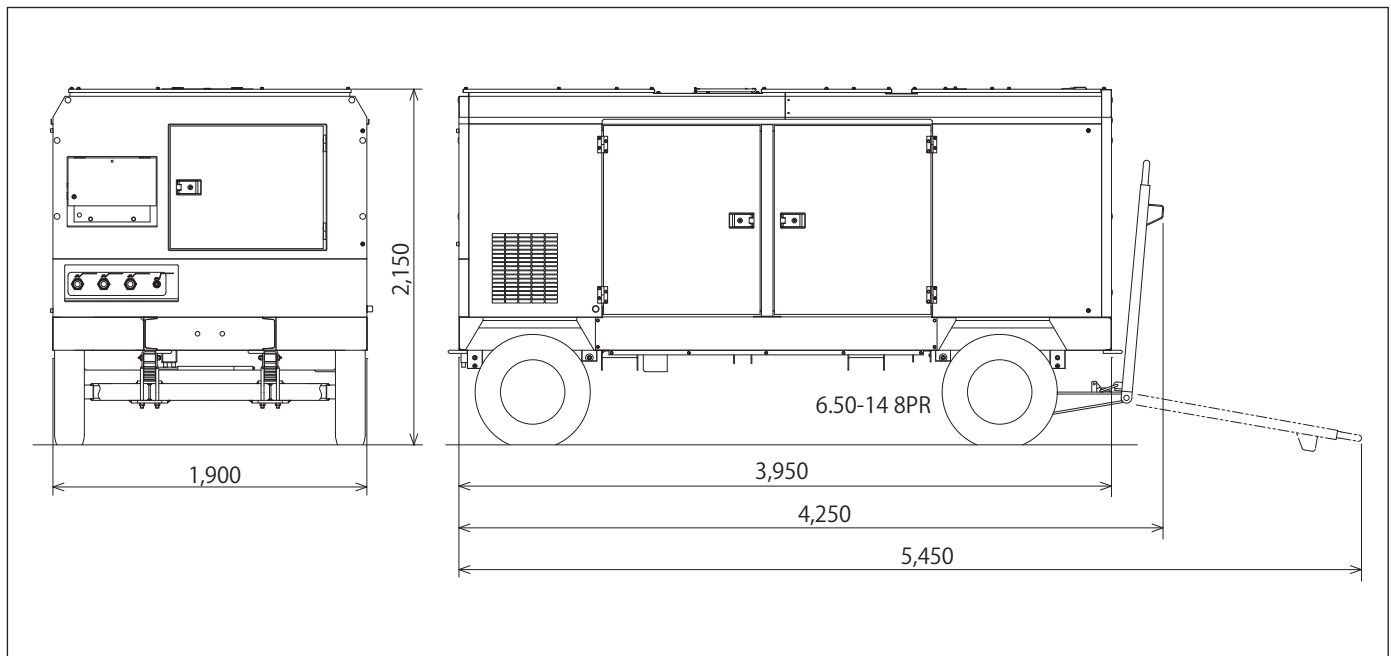

## SPECIFICATIONS PDSF920S-4B3

### COMPRESSOR

Type	Rotary twin screw, single stage, oil-cooled
Free air delivery	26.0 m <sup>3</sup> /min(920 cfm)
Working pressure	1.03 MPa(10.5 kgf/cm <sup>2</sup> G)(150 psi)
Unloader	Suction port closing in connection with stepless speed regulator
Lubrication system	Forced lubrication by compression pressure
Driving system	Direct coupling with rubber
Oil cooling	Air-cooled
Air cleaner	Dry paper filter type

### DIESEL ENGINE

Model	Mitsubishi 6D24-TLE2A
Type	Water-cooled, 4-cycle, Direct-Injection, Turbo-Charged, Intercooler type
No. of cylinders	6
Cyl. bore X stroke	130 mm x 150 mm
Total displacement	11.94 liters
Compression ratio	17.5 : 1
Rated output	238 kW/2,200 min <sup>-1</sup> (324 PS/2,200 rpm)
Max. torque	1,253 N·m/approx. 1,500 min <sup>-1</sup> (128 kgf·m/approx. 1,500 rpm)
Injection pump	Bosch type
Governor	Centrifugal, all-speed
Alternator	AC 24 V, 50 A
Starting motor	DC 24 V, 7.0 kW
Battery	170F51 x 2 pcs.
Air cleaner	Dry type
Fuel tank capacity	400 liters
Engine oil capacity (including oil cooler)	49 liters
Coolant capacity (including engine radiator)	45 liters
Compressor oil capacity (including receiver tank & oil cooler)	120 liters

### OIL SEPARATOR-RECEIVER TANK

Type	Vertical, cylindrical, full-welded
Shell dia.	Φ600 mm
Shell length	730 mm
Capacity	0.255 m <sup>3</sup>
Max. working pressure	1.58 MPa(13 kgf/cm <sup>2</sup> G)
Hydraulic test pressure	2.37 MPa(19.5 kgf/cm <sup>2</sup> G)
Air outlet valve	50 A x 3 pcs, 20 A x 1 pc

### INSTRUMENTS & GAUGES

#### EMERGENCY STOP DEVICES

Engine oil pressure switch, Delivery air temperature switch, Engine coolant temperature switch, Engine speed down switch, Disconnected of delivery air temperature sensor, Disconnected of engine coolant temperature sensor

#### WARNING LAMP

For engine coolant temperature rise, For delivery air temperature rise, For compressor filter clogging, For engine air filter clogging, For battery charging, For fuel level down

#### OPERATING LAMP

Glow lamp

#### GAUGES

Pressure gauge, Fuel gauge

#### MONITOR INDICATOR

Delivery air temperature, Engine coolant temperature, Engine speed, Hour meter

#### OPERATING SWITCH

Starter switch, Starting unloader valve, Monitor change switch, Error code indication switch, Engine error diagnosis switch (Alarm and Error)

### WEIGHT

Dry weight	4,250 kgs
Operating weight	4,750 kgs

## HOKUETSU INDUSTRIES CO., LTD.

8TH Floor Shinjuku San-Ei Bldg,  
22-2 Nishi-Shinjuku 1-Chome, Shinjuku-ku, Tokyo 160-0023 Japan  
TEL: 81-3-3348-7281 FAX: 81-3-3348-7289  
E-mail: [oversea@airman.co.jp](mailto:oversea@airman.co.jp)  
<http://www.airman.co.jp>

## HOKUETSU INDUSTRIES EUROPE B.V.

Breguetlaan 12, 1438 BC Oude Meer, The Netherlands  
PHONE: 31-20-6462636 FAX: 31-20-6462191  
e-mail: [info@hokuestu.nl](mailto:info@hokuestu.nl)

### SAFETY

- Operate safely in accordance with proper operation manual.
- To prevent trouble and accidents, perform daily and preventive maintenance checks without fail.



ISO9001 : JQA-0581  
ISO14001 : JQA-EM4670